

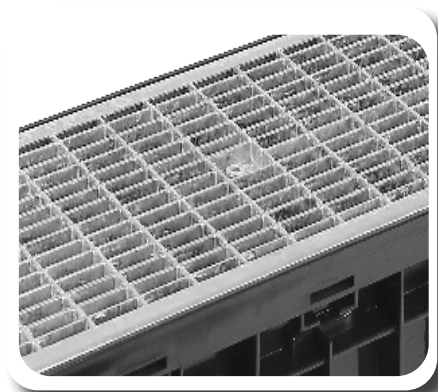

SAB drain
water drainage systems

601 GALVANISED GRATED CHANNEL

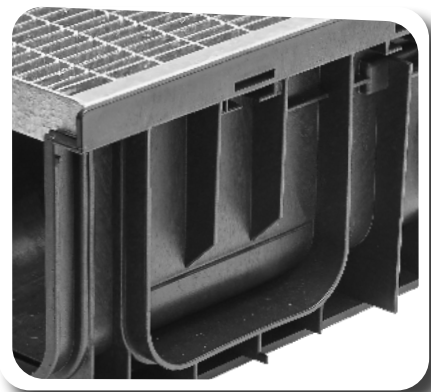
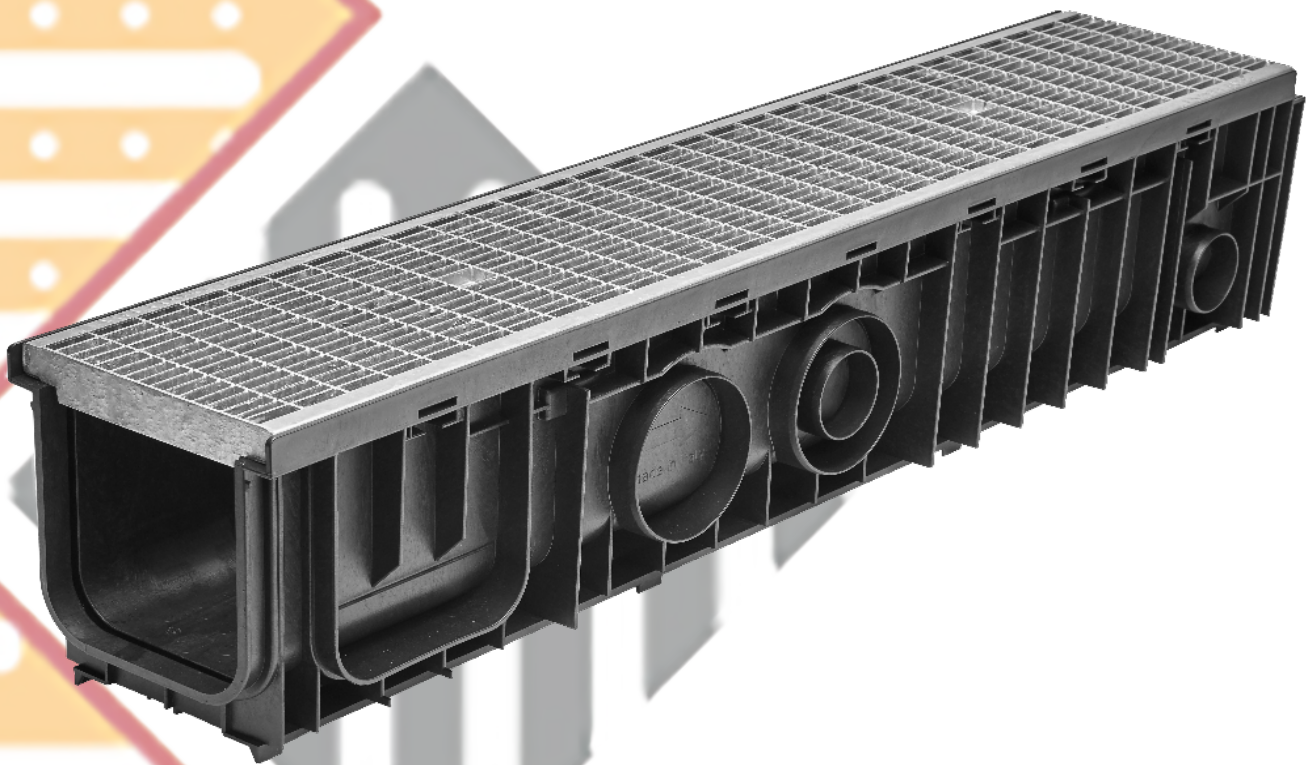

The details that make the difference.....

CLASS B GALVANISED DRAINAGE CHANNEL

SABdrain 601 combines the flexibility and durability of a polypropylene drainage channel unit whilst still being able to satisfy the strength requirements for situations that require accessibility for passenger and light commercial vehicles. This reliable Class B rated channel and grate has been designed to offer maximum versatility while delivering a lifetime of low maintenance service. Each galvanised gate comes with a 2 point security fixing, to keep it rattle free from vehicular movements and secure it from unauthorised access. Heel guard type grate, preventing heeled shoes & other objects from becoming caught in the grate. Ideal for driveway drainage, use around gardens, footpaths, schools, pathways, petrol stations, walkways, decks & outdoor areas, universities, aged care facilities, around equestrian stables, barns and much more.



B80



Heel Guard



Lockdown



Disability Compliant

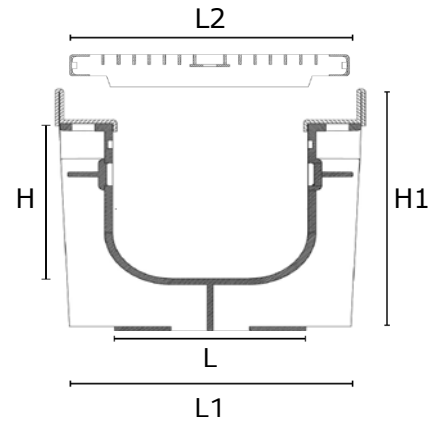
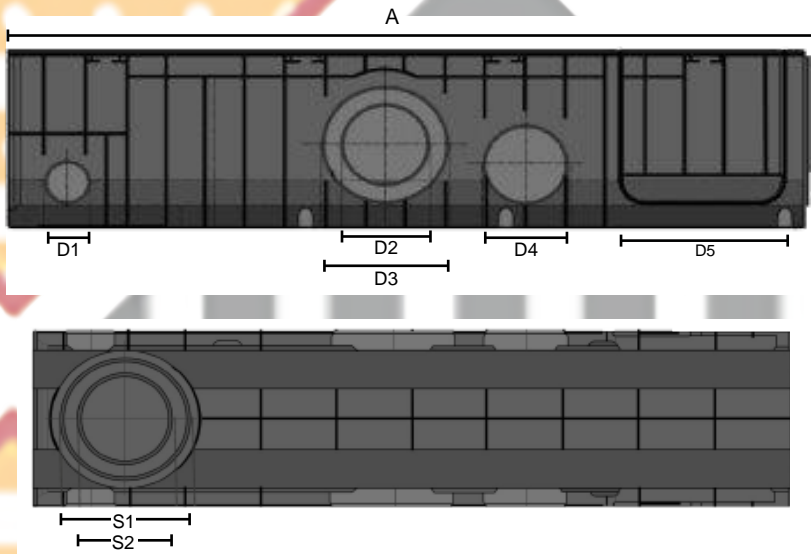

SABDRAIN 601															
CODE	L	H	L1	H1	L2	Drain cm ²	D1	D2	D3	D4	D5	S1	S2	A	KG
DR601100100	100	100	150	150	145	800	63	90	63	63	100	110	63	1000	6.4
DR601100150	100	150	150	200	145	800	63	110	63	110	100	110	63	1000	6.9
DR601150100	150	100	200	150	195	1241	63	90	63	63	150	110	63	1000	8.3
DR601150150	150	150	200	200	195	1241	63	110	63	110	150	110	63	1000	9.0
DR601200100	200	100	250	150	245	1485	63	90	63	63	200	160	110	1000	12.1
DR601200150	200	150	250	200	245	1485	63	110	63	90	200	160	110	1000	12.6
DR601200200	200	200	250	250	245	1485	63	160	110	90	200	160	110	1000	13.1
DR601200250	200	250	250	300	245	1485	63	160	110	90	200	160	110	1000	13.6
DR601200300	200	300	250	350	245	1485	63	160	110	90	200	160	110	1000	14.1

