

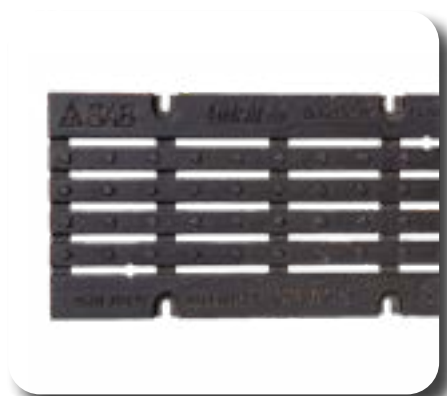

SABdrain
water drainage systems

707 CAST IRON HEEL GUARD GRATED CHANNEL



The details that make the difference.....

CLASS D CAST IRON HEEL GUARD DRAINAGE CHANNEL

SABdrain 707 provides the ultimate desirability for design and functionality of any drainage channel available to the civil construction market. From its lightweight channel unit to the high strength heel guard cast iron grate, the flexibility and durability of this product is able to offer the most demanding requirements placed upon it. This rated channel and grate has been designed to withstand fast heavy moving vehicles used in commercial areas along with motorways/highways meeting the Class D requirements. Each grate is equipped with 4 point security fixings system to keep this rattle free from vehicular movements and secured from unauthorised access.



Class C



Class D



Heel Guard



Anti-Slip



Lockdown



Disability Compliant

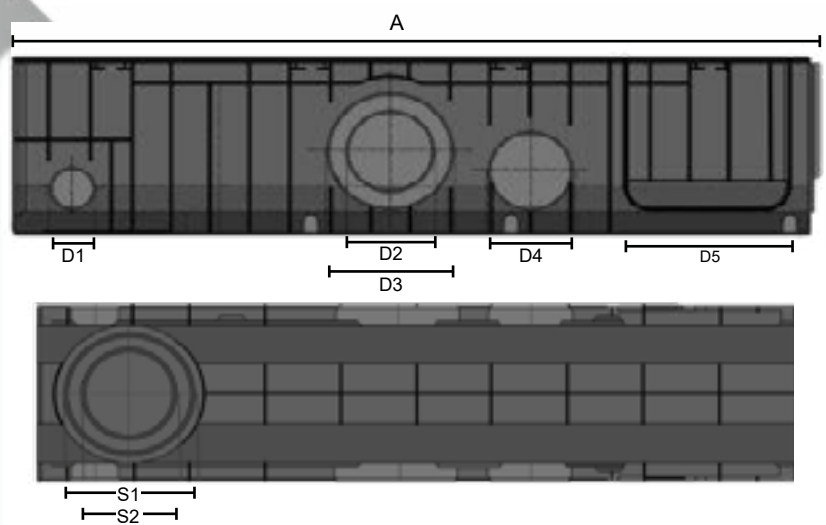
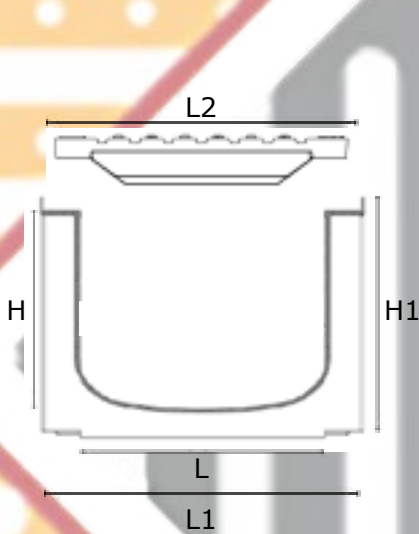

SABDRAIN 707

CODE	L	H	L1	H1	L2	Drain cm ²	D1	D2	D3	D4	D5	S1	S2	A	KG
DR707100100	100	100	150	150	147	81	63	90	63	63	100	110	63	1000	16.8
DR707100150	100	150	150	200	147	81	63	110	63	110	100	110	63	1000	17.3
DR707150100	150	100	200	150	197	137	63	90	63	63	150	110	63	1000	21.8
DR707150150	150	150	200	200	197	137	63	110	63	110	150	110	63	1000	22.5
DR707200100	200	100	250	150	247	191	63	90	63	63	200	160	110	1000	27.1
DR707200150	200	150	250	200	247	191	63	110	63	90	200	160	110	1000	27.6
DR707200200	200	200	250	250	247	191	63	160	110	90	200	160	110	1000	28.1
DR707200250	200	250	250	300	247	191	63	160	110	90	200	160	110	1000	28.6
DR707200300	200	300	250	350	247	191	63	160	110	90	200	160	110	1000	29.1

